

Lifting bottom centrifuge DS32 - DS150



 Metal Chip Treatment Leader in the World
40 Years Experience & Qualified Supplier



✓ Advantages

- long service life
- highly wear-resistant execution
- vibration-proof set-up
- universal operation
- suitable for grinding sludge
- best possible degree of dryness
- fully automatic and continuous operation
- compact design
- very low maintenance costs
- very easy to maintain
- self-cleaning

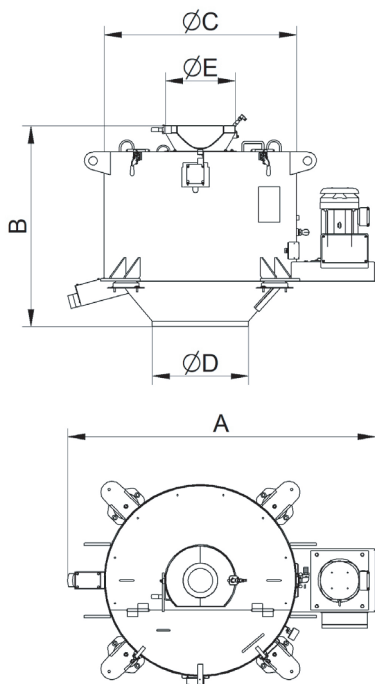

✓ Functional principle

In the fully automatic operation the wet chips or the sludge fall over the infeed hopper into the drum of the lifting bottom centrifuge. At this point the chips meet the rotating lifting bottom and are pressed against the drum wall under high centrifugal forces. The hydraulically activated lifting bottom moves the chips and/or the sludge upwards to the slot sieve where the liquids are separated from the chips. After a few lifting cycles the centrifuged chips are carried over the edge of the drum and quit the centrifuge into the chip cart or discharge conveyor. The centrifuged coolant can be returned to the production or pumped back to further treatment.

Type	Throughput* [kg/h]					Dimensions [mm]					Capacity [kW]	Weight [kg]
	Steel / Stainless steel	Aluminium	Grey cast iron	Brass	Grinding sludge	A	B	Ø C	Ø D	Ø E		
DS32	375	125	560	250	125	1.330	1.030	850	400	300	2,20	450
DS40	750	250	1.125	500	250	1.540	1.100	950	500	350	2,20	750
DS50	1.500	500	2.250	1.000	500	1.740	1.160	1.060	550	400	3,50	950
DS60	3.000	1.000	4.500	2.000	1.000	2.020	1.320	1.230	600	450	5,50	1.750
DS80	6.000	2.000	9.000	4.000	2.000	2.280	1.520	1.500	700	600	7,50	2.600
DS100	10.000	3.000	15.000	8.000	4.000	2.950	1.800	1.960	1.000	700	15,00	5.400
DS150	15.000	5.000	-	-	-	3.500	2.300	2.500	1.200	900	22,00	8.500

* Throughput depending on kind of material and coolant