

Batch wringer centrifuge ME41 - ME81



 Metal Chip Treatment Leader in the World
40 Years Experience & Qualified Supplier



✓ Advantages

- turnkey delivery and easiest handling
- perfect application for manual or half-automatic de-oiling or drying and conservation of turning workpieces, stampings and blanks
- very long service life, operation free of vibrations
- compact and easy to maintain, i.e. low maintenance costs and quick return of investment
- dryness up to 1% residual moisture possible
- standard execution consists of lid with pneumatic spring and electro-magnetic lid locking, unbalance detection switch and standstill control

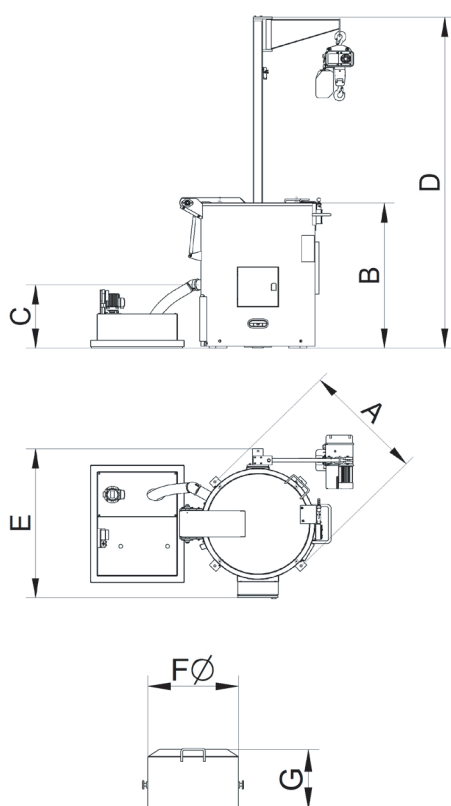

✓ Functional principle

The basket can be elevated into the centrifuge using a lifting hook. When the drum is placed into the centrifuge an individually set centrifuging time begins to run. After completion of the centrifuging process, the drum is taken out and the process can be repeated with the next wet material.

Batch wringer are constructed for a long lasting continuous operation. The electro-magnetic lid locking, an unbalance detection switch and the standstill control provide maximum operational safety.

Optional accessories are available:

Rotation speed controller, crane support with pivot arm or an electric chain hoist, heating, tank, transport cart for the drum or customised carrier e.g. for boxes or workpieces. Even custom build models in stainless steel are available on request.

Type	Content weight (kg)	Drum-volume (l)	Batches / h * (max)	Dimensions [mm]							Capacity (kW)	rpm max. (min) *
				A	B	C	D	E	ØF	G		
ME41	50	35	10	680	990	500	2.525	934	400	300	2,20	980
ME51	100	60	10	800	1.045	485	2.525	1.126	500	350	4,00	980
ME61	200	100	8	910	1.115	485	2.525	1.156	600	410	5,50	740
ME81	300	150	8	1.004	1.265	500	-	1.460	800	500	7,50	740

* Can differ according to the type of chip and specific weight